

P5 - P1 MECHANISM

SCREW THE 3 SCREWS IN THE SEAT THROUGH THE BACK BAR

MAKE SURE THAT SCREWS ARE INSTALLED IN THE ORDER SHOWN BELOW

Available on:

- FX
- X2
- Spyder
- Urbex
- Lead

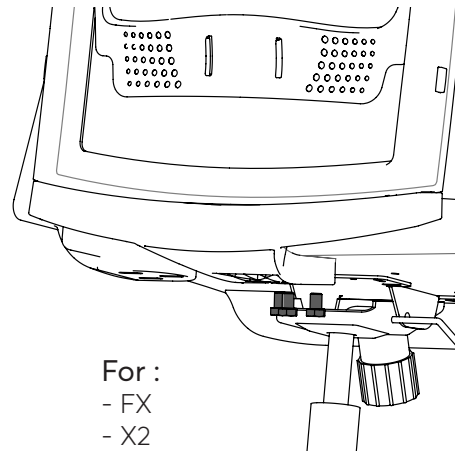

For :
- FX
- X2

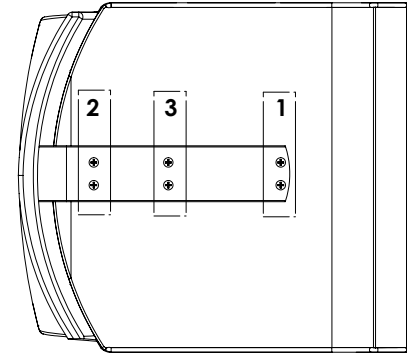

For :
- Spyder
- Urbex
- Lead

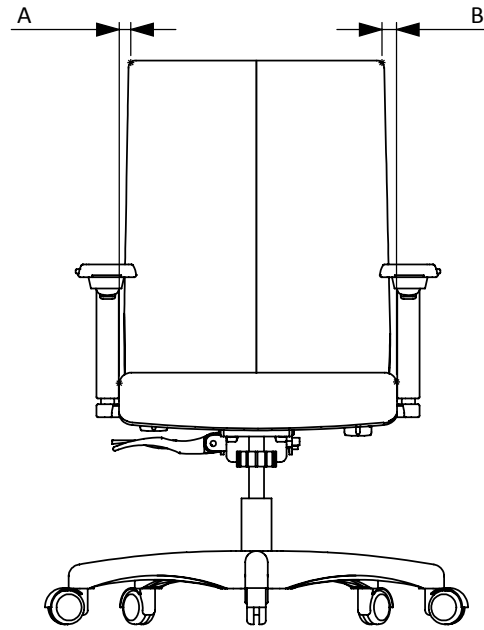

Make sure that the distance between section A and B is equal.

IMPORTANT: Note that the screws are already inserted in their proper holes. (Unscrew them and rescrew in position with a hammer drill)

ROUILLARD

INSTALLATION GUIDE

CYLINDER, BASE & CASTER

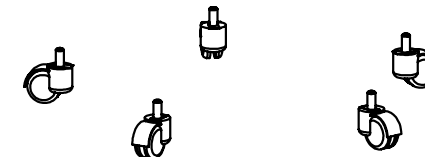
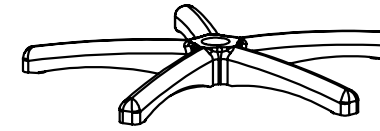
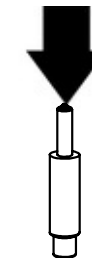
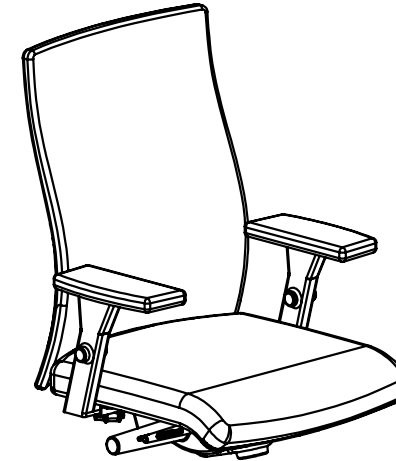

IMPORTANT: Remove the cap on the cylinder.

P2 - PRG - P8 MECHANISM

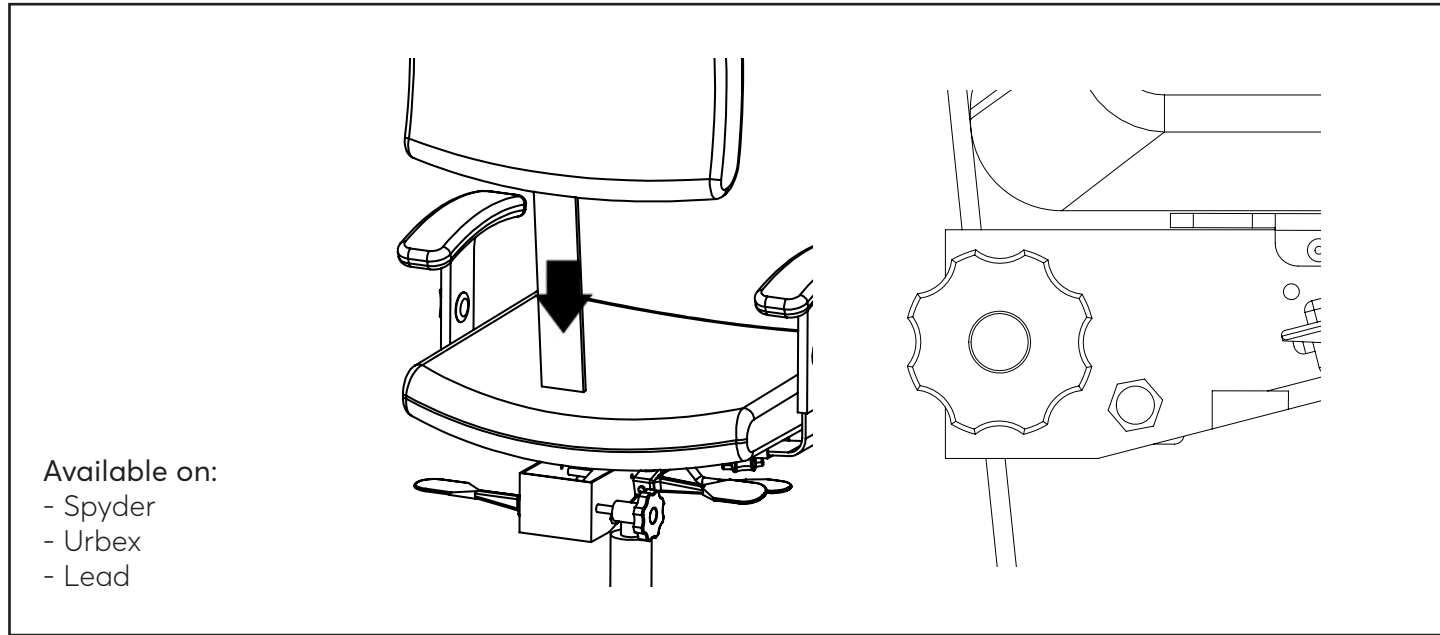

Available on:
 - Spyder
 - Urbex
 - Lead

PZ MECHANISM

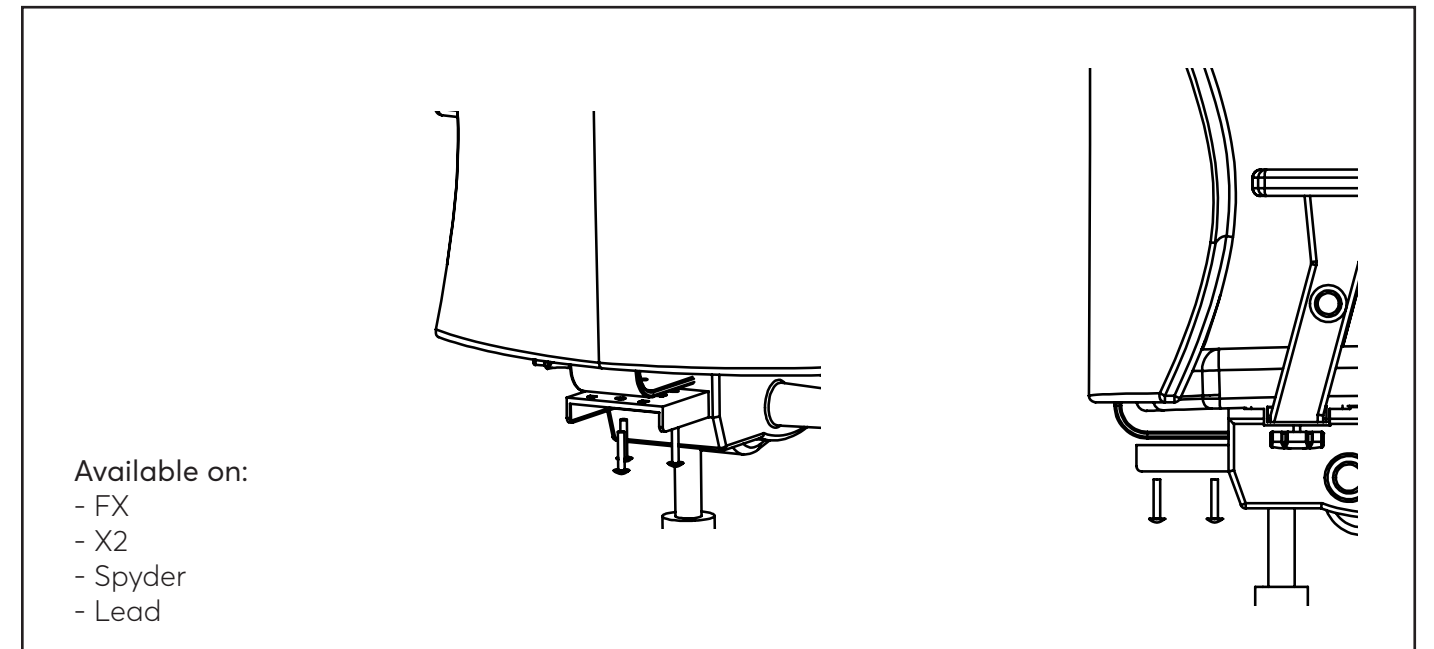

Available on:
 - FX
 - X2
 - Spyder
 - Lead

PGG - PFG - PE MECHANISM

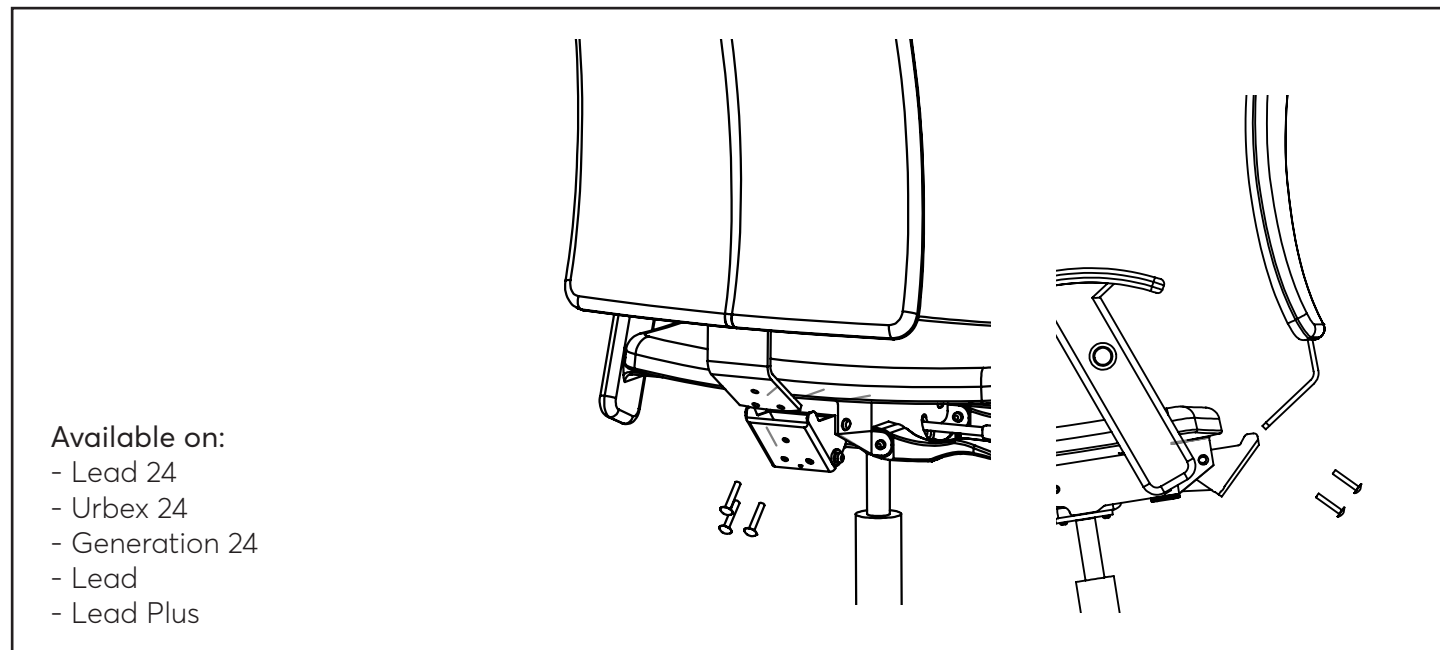

Available on:
 - Lead 24
 - Urbex 24
 - Generation 24
 - Lead
 - Lead Plus

PD MECHANISM

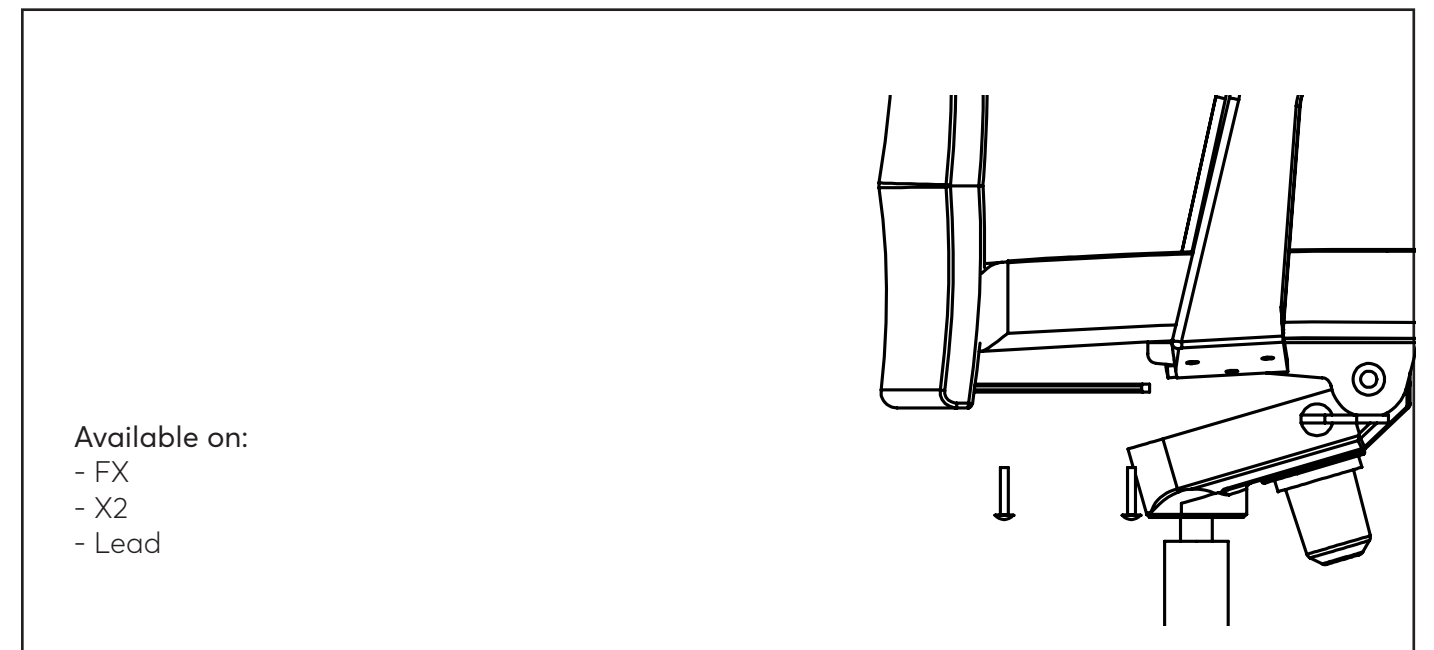

Available on:
 - FX
 - X2
 - Lead

IMPORTANT: Note that the screws are already inserted in their proper holes.
 (Unscrew them and rescrew in position with a hammer drill)

IMPORTANT: Note that the screws are already inserted in their proper holes.
 (Unscrew them and rescrew in position with a hammer drill)